

User Manual

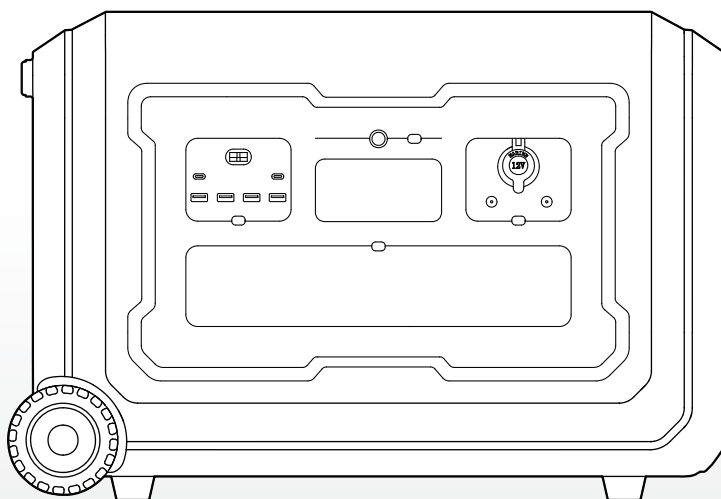

S 3

3600W Portable Power Station

Contents

APP&Product List	01
Product Description	02-04
Specifications	02
Overview	03
LCD Screen	04
Instructions for Use	05-06
Circuit Breaker Protection	05
Power ON/OFF	05-06
Frequency Switching	06
Recharge Methods	07-10
AC Charging	07
Solar Charging	08
Cigarette Lighter Charging	09
Extra Battery Charging	09
Gasoline Inverter Generator Charging	10
EPS(Emergency Power Supply)	11
Error Code & Trouble Shooting	12-13
FAQ(Frequently Asked Question)	14

Disclaimer

Disclaimer

Before using this product, please read this user manual carefully to ensure that you fully understand the product and can use it correctly. After reading this user manual, please keep it in a safe place for future reference. Improper use of this product may cause serious injury to yourself or others, or result in product damage and property loss. By using this product, you are deemed to have understood, recognized and accepted all the terms and contents of this document. The Company shall not be responsible for any damages caused by the user's failure to use this product in accordance with this user manual.

In accordance with laws and regulations, the company reserves the right of final interpretation of this document and all documents related to this product. This document is subject to change, update, revision or termination without notice.

Please visit our website for the latest product information.

- The company shall not be held responsible for any damage caused by force majeure (e.g. fire, typhoon, flood, earthquake) or use under other abnormal circumstances by the customer.

Transportation

1. Do not subject this product to severe impacts, vibrations, or drops.
2. Do not carry this product onto a plane.

Environment

3. Keep the product away from water resources, heat resources, metal objects and chemical substances and dust environment.
4. Place the product on a stable and flat surface.
5. Store the product in a dry, well-ventilated place.
6. Follow the environment temperature requirements specified in the user manual.
7. Do not use the product in an environment with strong static electricity or magnetic fields.
8. Keep the product out of reach of children and pets.

Operation

9. Do not damage, repair, modify or disassemble this product by yourself.
10. Do not use any unofficial or not recommended components or accessories.
11. Remember to turn on the product before connecting your devices.

Disclaimer

12. Always disconnecting your devices before turning off the product.
13. Do not put fingers or hands into the product.
14. Do not insert wires or other metal objects into the product to prevent short circuits.
15. Do not use the product to power medical equipment and precision instrument.
16. Do not stack any heavy objects on the product.
17. Risk of Electric Shock: Never use the product to power tools to cut or access live parts or live wirings, or materials that may contain live parts or live wirings inside, such as building walls, etc.

Emergency

18. If the product falls into water or gets wet, stop using it immediately and place the product in a secure, waterproof, and well-ventilated area, then contact customer service for further support.
19. If the product is smoking or catches fire, it is recommended to use the fire extinguishers.
20. If the product is overturned and severely damaged, wear insulating gloves to turn it off, and then place the product in an open area far from flammable materials and people, and dispose of it according to local laws and regulations.

Recycling and Disposal

21. The product with severe damage, malfunction, or depleted battery life should be properly disposed of or recycled.
22. The product contains batteries. Please dispose of the product following local laws and regulations for battery disposal and recycling. Do not dispose of it with household waste to avoid environmental pollution and safety hazards.
23. If possible, ensure the battery is completely discharged (to 0% capacity) before disposing of the product. If not, refrain from placing the battery directly into a battery recycling box. Instead, contact a professional battery recycling company for proper handling.

APP&Product List

⚡ APP

You can connect this product via APP to view information, control the device and personalize settings.



[Scan the QR code to download our Smart Control APP.](#)

Product List

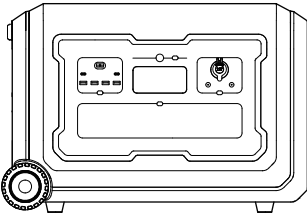

Power Station*1

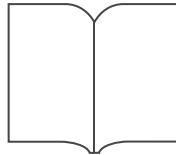

User Manual*1



Warranty Card*1

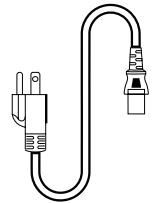

AC Charging Cable
*1

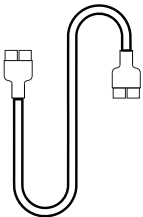

Anderson to Anderson
Cable*1

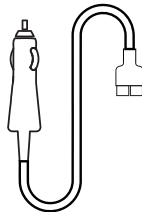

Cigarette Lighter to
Anderson Cable*1

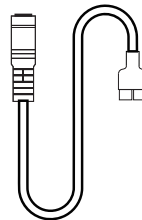

7909 to Anderson
Cable *1

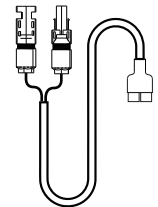

MC4 to Anderson
Cable *1

Product Description

⚡ Specifications

Output

AC Output	220V~240V 50Hz/60Hz
	3600W Max (Surge: 7000W)
	Bypass Mode: 3600W
DC 12V & Cigarette Lighter Output	12V10A 120W Total
3×USB-A Output	5V3A; 9V2A; 12V1.5A 18W Per Port
1×USB-A Output	5V2A
2×USB-C Output	5V3A; 9V3A; 12V3A; 20V5A 100W Per Port
Anderson Output	12V30A

Input

AC Input	220V~240V 50Hz 13A Max 2500W Max
Solar Input	12V~148V MPPT: 18V~140V 15A Max 2100W Max
Cigarette Lighter Input	12V~15V 8A Max

General Info

Battery Capacity	3072Wh (51.2V/60Ah)
Battery Type	LiFePO4
Working Temperature	32°F~104°F (0°C~40°C)
Storage Temperature	-4°F~140°F (-20°C~60°C)
Dimension	Approx.25.2*11.9*17.2in (641.5*304.5*437.5mm)
Net Weight	Approx.83.33lb (37.8kg)

Product Description

⚡ Overview

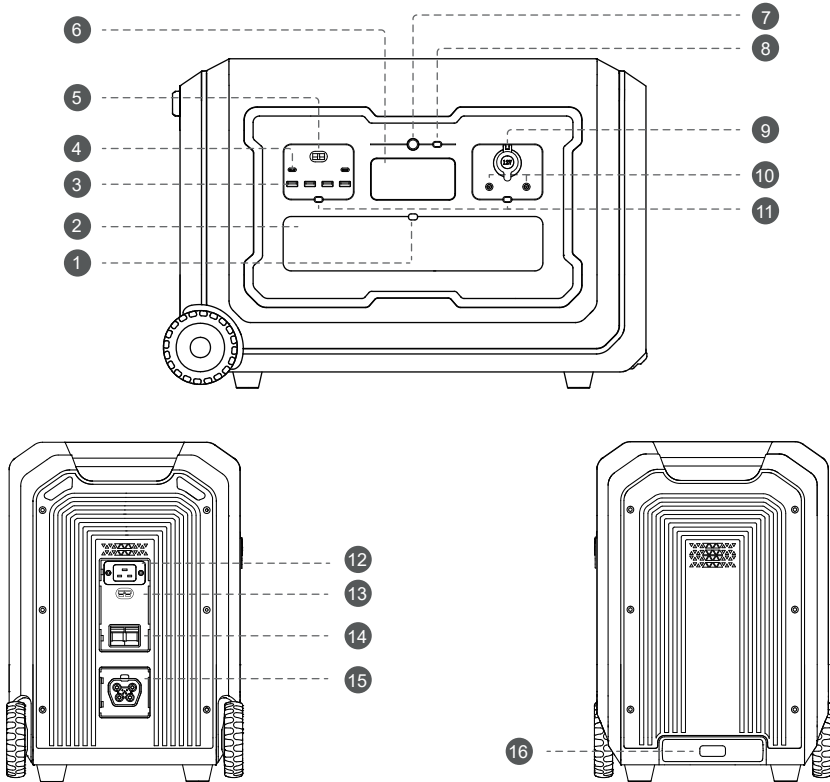

1. AC Output Power Button

2. AC Output Socket

3. USB-A Output Port

4. USB-C Output Port

5. Anderson Output Port

6. LCD Screen

7. Main Power Button

8. IOT Button

9. Cigarette Lighter Output Port

10. DC 5521 Output Port

11. DC Output Power Button

12. AC Input Port

13. Solar/Car Input Port

14. Circuit Breaker

15. Extra Battery Port

16. Handle

Product Description

⚡ LCD Screen

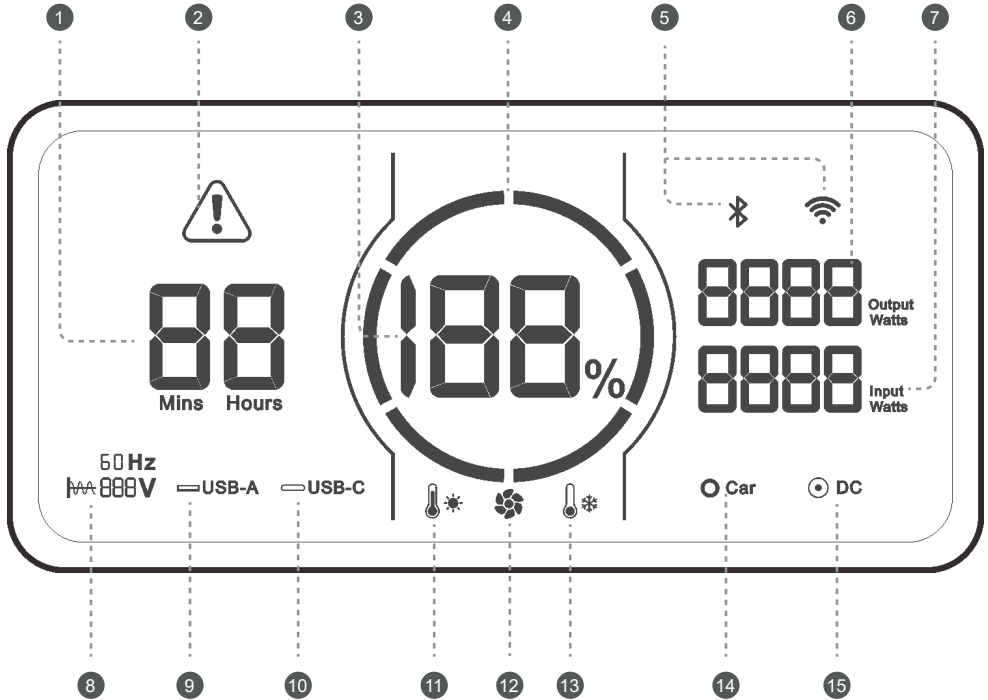

- | | |
|--------------------------------|---------------------------------|
| 1. Charge/Discharge Time Left | 9. USB-A Indicator |
| 2. Error Warning | 10. USB-C Indicator |
| 3. Battery Capacity Percentage | 11. High Temperature Indicator |
| 4. Battery Capacity Circle | 12. Cooling Fan |
| 5. WiFi & Bluetooth | 13. Low Temperature Indicator |
| 6. Output Power Display | 14. Cigarette Lighter Indicator |
| 7. Input Power Display | 15. DC 5521 Indicator |
| 8. AC Output Indicator | |

When the power station is charging and discharging simultaneously, it displays the remaining charge time if the input power exceeds output power; Otherwise, it shows a fixed number "99".

Instructions for Use

Circuit Breaker Protection

- 1 Flip up AC IN breaker and AC OUT breaker before using the product.
- 2 When AC input or AC output exceeds 40A, AC IN breaker or AC OUT breaker will flip down automatically.
- 3 Please disconnect all the connections for safety reason, and ensure that the current is lower than 40A. Then flip up the AC IN or AC OUT breaker to resume using.

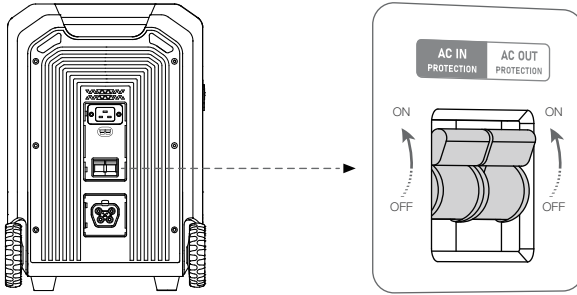

Power ON/OFF

Main Power:

- 1 Press and hold the main power button for 3 seconds to turn the main power on or off.
- 2 When the main power is on, short press the main power button to turn the screen on or off.
- 3 The product will shut down after 5 minutes without operation.

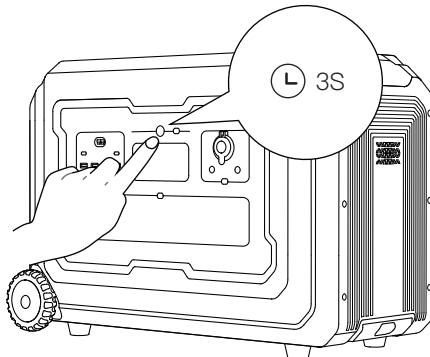

Instructions for Use

AC/DC Output Power:

- 1 When the main power is on, press AC/DC output power button to turn on, press them again to turn off.
- 2 The product will shut down after 12 hours without any load connected, which can be adjusted on the APP.

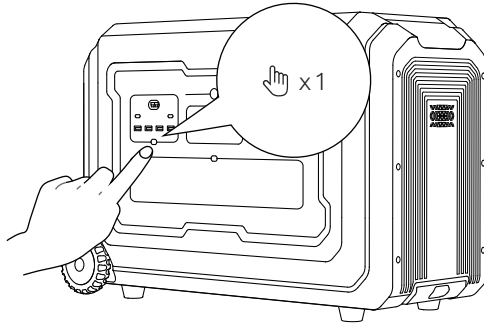

Frequency Switching

- 1 Turn off the AC and DC output power.
- 2 Simultaneously press and hold DC output power button on USB side and main power button for 3–5 seconds, till the frequency sign flashes on the screen.
- 3 Press AC output power button to choose frequency “50” or “60”.
- 4 Long press the main power to confirm, then the abbreviation “SUC” will flicker, indicating a successful setting.
- 5 Long press the main power button to exit the setting mode.

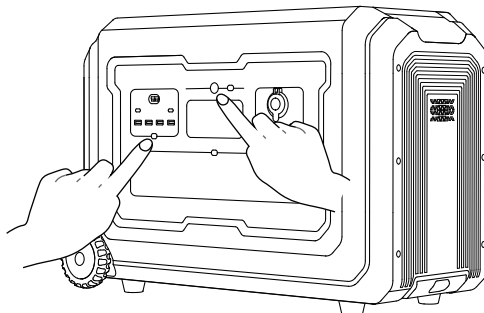

Recharge Methods

⚡ AC Charging

Use AC charging cable to connect AC wall outlet and the power station.

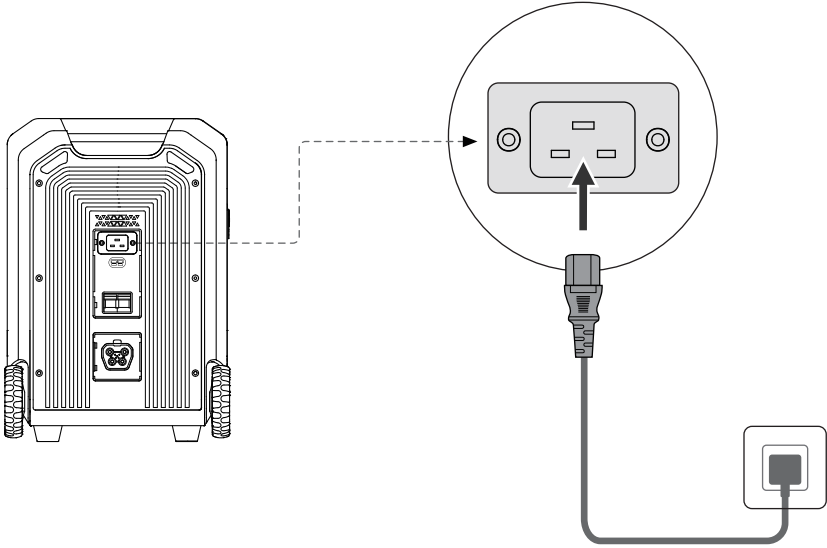

Recharge Methods

⚡ Solar Charging

- 1 Use MC4 to Anderson charging cable to connect solar panels and the power station.
- 2 Connect 6*240W solar panels at most in series to get maximum power.
- 3 Make sure the solar panels meet the following requirements:
OCV: 148V; Current: 15A; Max Power: 2100W

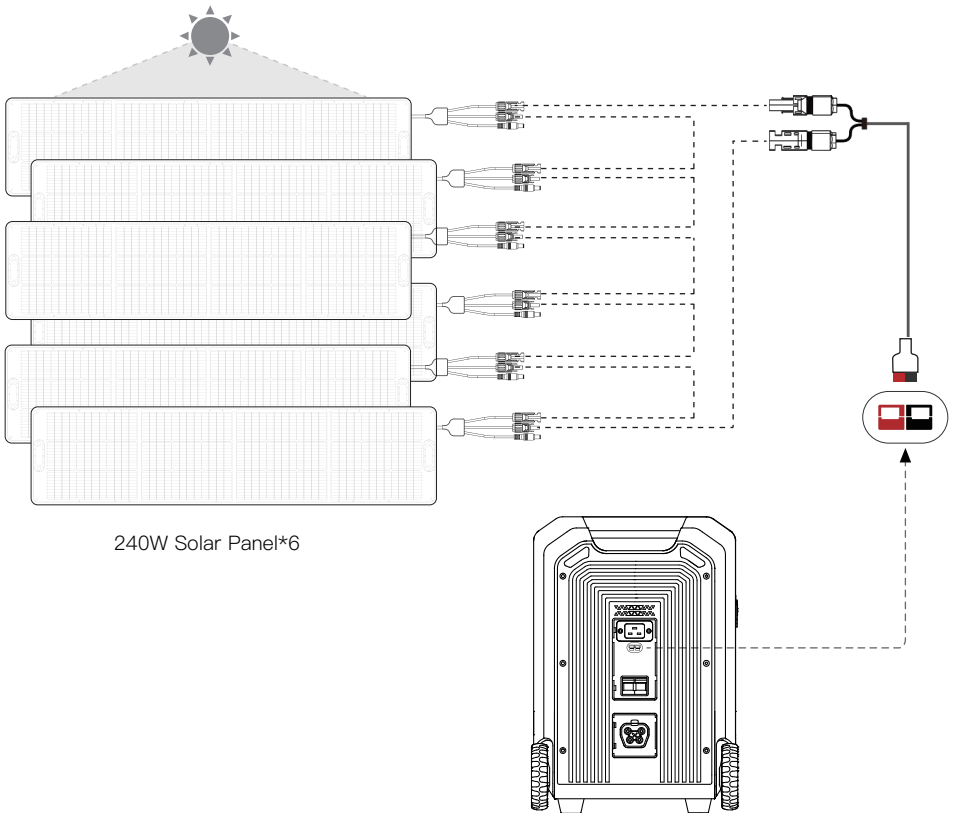

Recharge Methods

⚡ Cigarette Lighter Charging

- 1 The cigarette lighter port supports 12V~15V, 8A car charging input.
- 2 Start the car first, then connect the cable and cigarette lighter. Make sure they're in good connection.

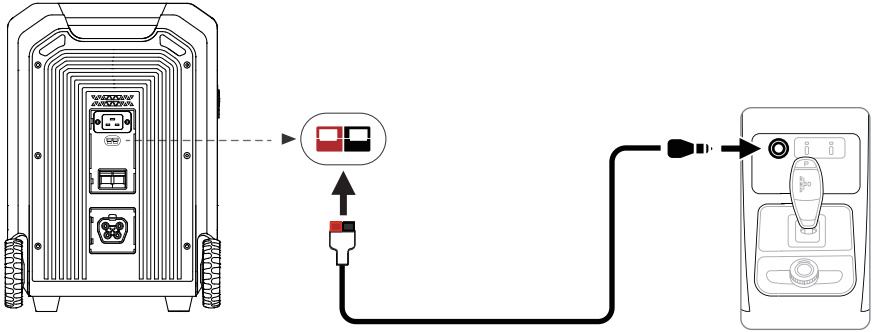

⚡ Extra Battery Charging

- 1 Turn off the power station and the extra battery before connecting or disconnecting them.
- 2 Use battery expansion cable to connect the extra battery and the power station.

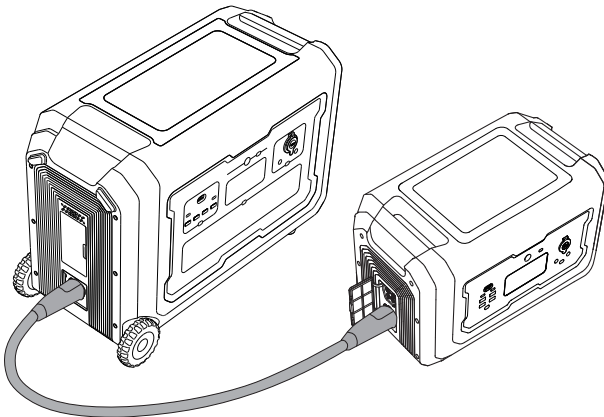

Recharge Methods

⚡ Gasoline Inverter Generator Charging

- 1 Turn off the power station and the generator before connecting or disconnecting them.
- 2 Use battery expansion cable to connect the generator and the power station, and refer to the generator's user manual before using the generator.
- 3 When detecting the power station only have 20% capacity left, the generator will starting charging the power automatically; And it will stop charging when the power station is charged to 90%.

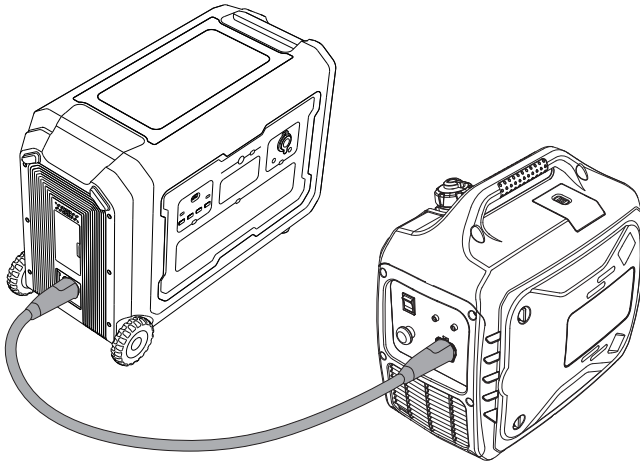





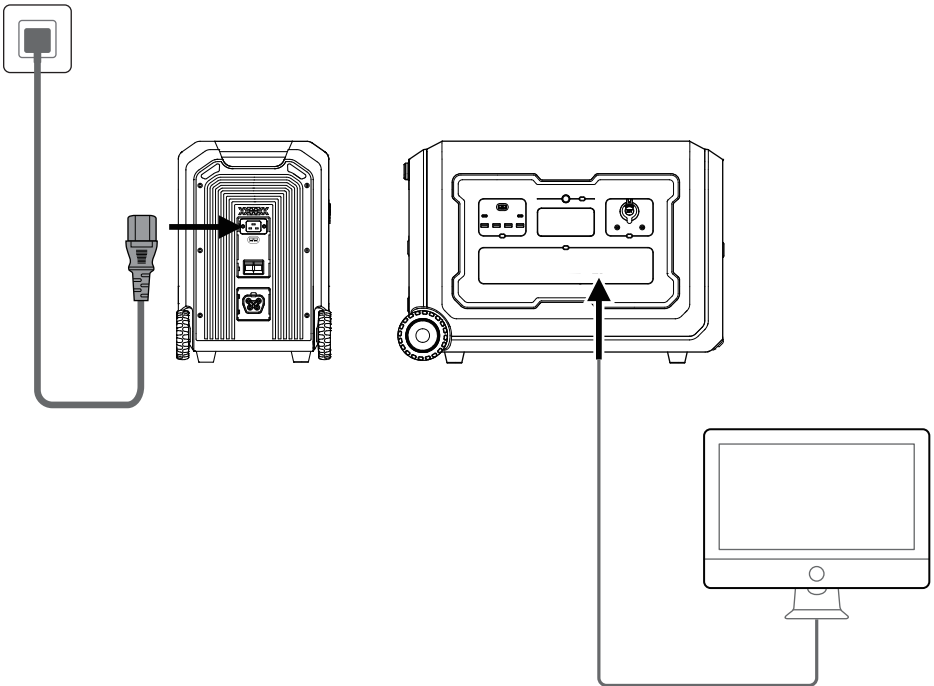































EPS(Emergency Power Supply)

























- 1 EPS function is enabled by default with a 20ms switching when grid power is cut off.
- 2 Flip up AC IN and AC OUT breakers.
- 3 Charge the power station from power grid and connect the device to AC output port as shown in the picture, then press AC output power button on.
- 4 Please do not connect the power station to equipment requiring 0ms uninterrupted power supply. Please make sure the device is compatible with EPS function.
- 5 The total input and output power should lower than 3600W. Otherwise, the power station will shut down in 1 minute.



Error Code & Trouble Shooting

Error Code	Status	Cause	Solution
E000	 +  +  flashing, no output	Short circuit of AC output.	Press the AC output power button to restore.
E001	 +  +  flashing, no output	Overload of AC output.	Press the AC output power button to restore.
E002	 +  +  flashing, no output	Battery voltage of inverter input is low.	Charge the device in time and restart the corresponding function button to restore.
E003	 +  +  flashing, no output	Over voltage and under voltage of AC output.	Press the AC output power button to restore.
E004	 +  +  flashing, no input	Abnormal AC input frequency.	Automatically restores after frequency returning to normal.
E005	 +  flashing, no output	High and low bus voltage.	Press the AC output power button to restore.
E006	 +  +  +  flashing, no output	Over temperature of Inverter.	Turn off output power and rest the device to restore.
E008	 +  flashing, no output	Overload and short circuit of 12V/30A output port.	Press the DC output power button to restore.
E009	 flashing	Overload or short circuit of 24V auxiliary power.	Reduce the loads on DC output port.
E010	 +  +  +  flashing, no output	Overload or short circuit of the cigarette lighter output port.	Press the DC output power button to restore.
E011	 +  +  flashing, no output	Overload or short circuit of the USB-A port.	Press the DC output power button to restore.
E012	 +  +  flashing, no output	Overload of the USB-C port.	Press the DC output button to restore.
E020	 +  flashing	BMS communication failure.	Contact after sales service team for further support.

Error Code & Trouble Shooting

Error Code	Status	Cause	Solution
E021	 +  flashing	Over voltage of single battery cell.	Stop charging and discharge until the battery voltage returns to normal.
E022	 +  flashing, no output	Low voltage of single battery cell.	Charge the device until the voltage returns to normal.
E023	 +  flashing	Battery total voltage too high.	Stop charging and start discharging until the battery voltage returns to normal.
E024	 +  flashing, no output	Battery total voltage too low.	Charge the device until the voltage returns to normal.
E025	 +  +  flashing, no output	High temperature of battery.	The device will automatically return to normal when the temperature returns to normal.
E026	 +  +  flashing, no output	Low temperature of battery.	The device will automatically return to normal when the temperature returns to normal.
E027	 +  +  flashing, no AC output. DC output is normal.	System overload, AC output is over 4000VA or the total AC and DC output is over 4000W.	Reduce AC loads and press the AC power button to restore.
E028	 +  +  flashing, no input	Charge over temperature.	Charge the device after the temperature returning to normal.
E029	 +  +  flashing, no input	Over temperature of MOSFET.	The device will automatically return to normal when the temperature returns to normal.
E030	 +  flashing	Connect the wrong expansion battery.	Connect correct extra battery to restore.

If the issue persists, contact support.

1.How to clean the product?

Please use a dry, soft, clean cloth or paper towel to gently wipe the product.

2.How to store the product?

Store it in a dry, well-ventilated place at room temperature. The recommended storage temperature is $-4^{\circ}\text{F}\sim 140^{\circ}\text{F}$ ($-20^{\circ}\text{C}\sim 60^{\circ}\text{C}$) and keep it away from water resources, heat resources, metal objects and chemical substances.

3.How to maintain the product?

- (1) Charge it to around 60% capacity and turn off the product before storing it.
- (2) For long-term storage, it is recommended to fully discharge and then fully charge the battery(0%–100%) once every 3 months.
- (3) And the warranty will be voided if the product has not been charged or discharged in 6 months.

4.Can this product be charged using a gasoline or diesel generator?

Yes, it can be charged with a generator that has a built-in pure sine wave inverter. The company will not be responsible for any product damage caused by using a generator without this feature.

5.Can this product be brought on board a plane?

No, this product cannot be brought on board a plane due to aviation regulations for lithium-based batteries.

6.How to place the product?

It is advised to place the product horizontally.

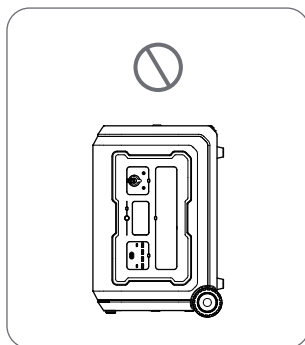
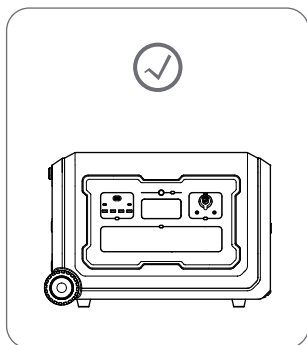

此页内容不印刷

批准	伍鹏达	审核	确认	制作	邓钰臻	WeledPower® 深圳伟鹏世纪科技有限公司	标签规格	大小: 148*210mm
								比例: A5纸张 材质: 封面120g光面双铜,内部80g书写纸
变更记录	④						工艺要求	骑马订 彩色印刷
	③							机型号
	②						料号	
	①							版本
日期	2025/08/22			制作完成		制作人: 邓钰臻		